

XPedite5500

Freescale QorIQ P2020 Processor-Based Air-Cooled XMC/PrPMC Module

- › Freescale QorIQ P2020/P2010 processor with dual/single PowerPC e500 cores at up to 1.2 GHz
- › Air-cooled
- › Extended shock and vibration tolerance
- › Up to 8 GB of DDR3-800 ECC SDRAM
- › PCI PrPMC interface
- › Two Gigabit Ethernet ports to P14
- › Two RS-232 serial ports to P14
- › One USB 2.0 port
- › Up to 512 MB of NOR flash (with redundancy)
- › Up to 16 GB of NAND flash
- › Detachable front panel for development
- › Linux BSP
- › Wind River VxWorks BSP
- › QNX Neutrino BSP
- › Green Hills INTEGRITY-178 BSP

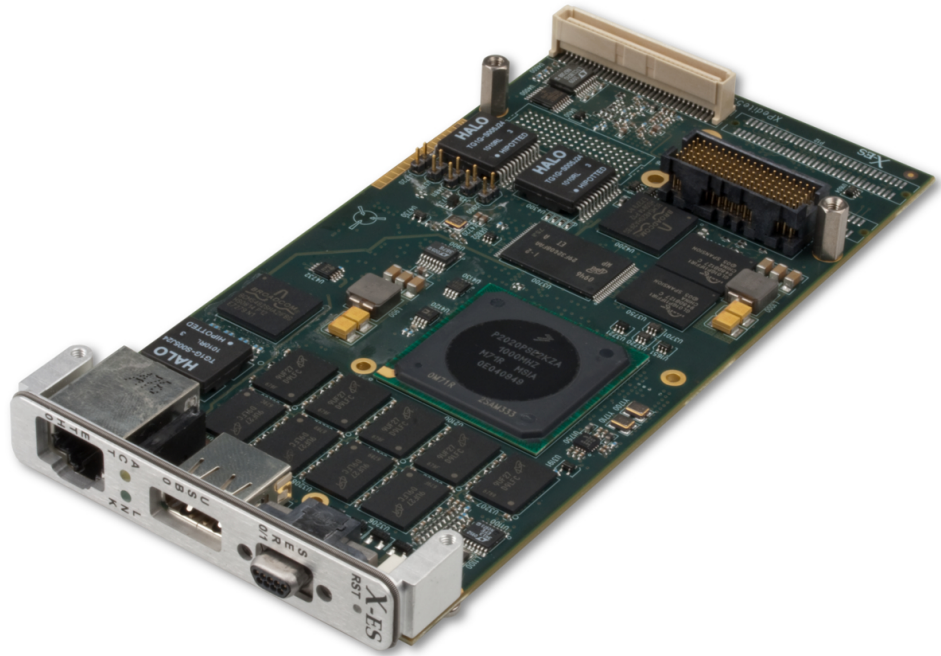

XPedite5500

The XPedite5500 is an XMC/PrPMC mezzanine module targeting the Freescale QorIQ P2020 processor. With dual PowerPC e500 cores running at up to 1.2 GHz, the P2020 delivers enhanced performance and efficiency for today's network information processing and other embedded computing applications.

Complementing processor performance, the XPedite5500 features up to 8 GB of DDR3-800 ECC SDRAM. A conventional PCI interface to the PMC connectors provides ample bandwidth to the P2020. Two Gigabit Ethernet ports, a USB 2.0 port, and two RS-232 ports are routed to P14 for additional system flexibility. A detachable front panel provides one Gigabit Ethernet port and two RS-232 serial ports for development.

The XPedite5500 provides a high-performance, feature-rich solution for current and future generations of embedded applications. Operating system support packages for the XPedite5500 include Wind River VxWorks, QNX Neutrino, Green Hills INTEGRITY-178, and Linux 2.6.

X-ES

Extreme Engineering Solutions

...Always Fast

Extreme Engineering Solutions

3225 Deming Way, Suite 120 • Middleton, WI 53562
 Phone: 608.833.1155 • Fax: 608.827.6171
 sales@xes-inc.com • <http://www.xes-inc.com>

Processor

- Freescale QorIQ P2020/P2010 processor
- Dual/single PowerPC e500 cores at up to 1.2 GHz
- 512 kB of shared L2 cache

Memory

- Up to 8 GB of DDR3-800 SDRAM
- Up to 512 MB of NOR flash (with redundancy)
- Up to 16 GB of NAND flash

PrPMC Interface

- 33/66 MHz PCI
- 32-bit bus interface

P14/P16 XMC/PrPMC Interface

- Two RS-232/422/485 ports
- 3.3 V GPIO
- Two Gigabit Ethernet ports

Front Panel I/O

- One Gigabit Ethernet port to P14
- Two RS-232 serial ports to P14
- One USB 2.0 port

Software Support

- Linux BSP
- Wind River VxWorks BSP
- QNX Neutrino BSP
- Green Hills INTEGRITY-178 BSP

Physical Characteristics

- Air-cooled XMC/PMC form factor
- Dimensions: 149 mm x 74 mm

Environmental Requirements

Contact factory for appropriate board configuration based on environmental requirements.

- Supported ruggedization levels (see chart below): 1, 3, 5
- Conformal coating available as an ordering option

Power Requirements

- Power will vary based on configuration and usage. Please consult factory.

Ruggedization Level	Level 1	Level 3	Level 5
Cooling Method	Standard Air-Cooled	Rugged Air-Cooled	Conduction-Cooled
Operating Temperature	0 to +55°C ambient (300 LFM)	-40 to +70°C (600 LFM)	-40 to +85°C (board rail surface)
Storage Temperature	-40 to +85°C ambient	-55 to +105°C ambient	-55 to +105°C ambient
Vibration	0.002 g ² /Hz, 5 to 2000 Hz	0.04 g ² /Hz (maximum), 5 to 2000 Hz	0.1 g ² /Hz (maximum), 5 to 2000 Hz
Shock	20 g, 11 ms sawtooth	30 g, 11 ms sawtooth	40 g, 11 ms sawtooth
Humidity	0% to 95% non-condensing	0% to 95% non-condensing	0% to 95% non-condensing

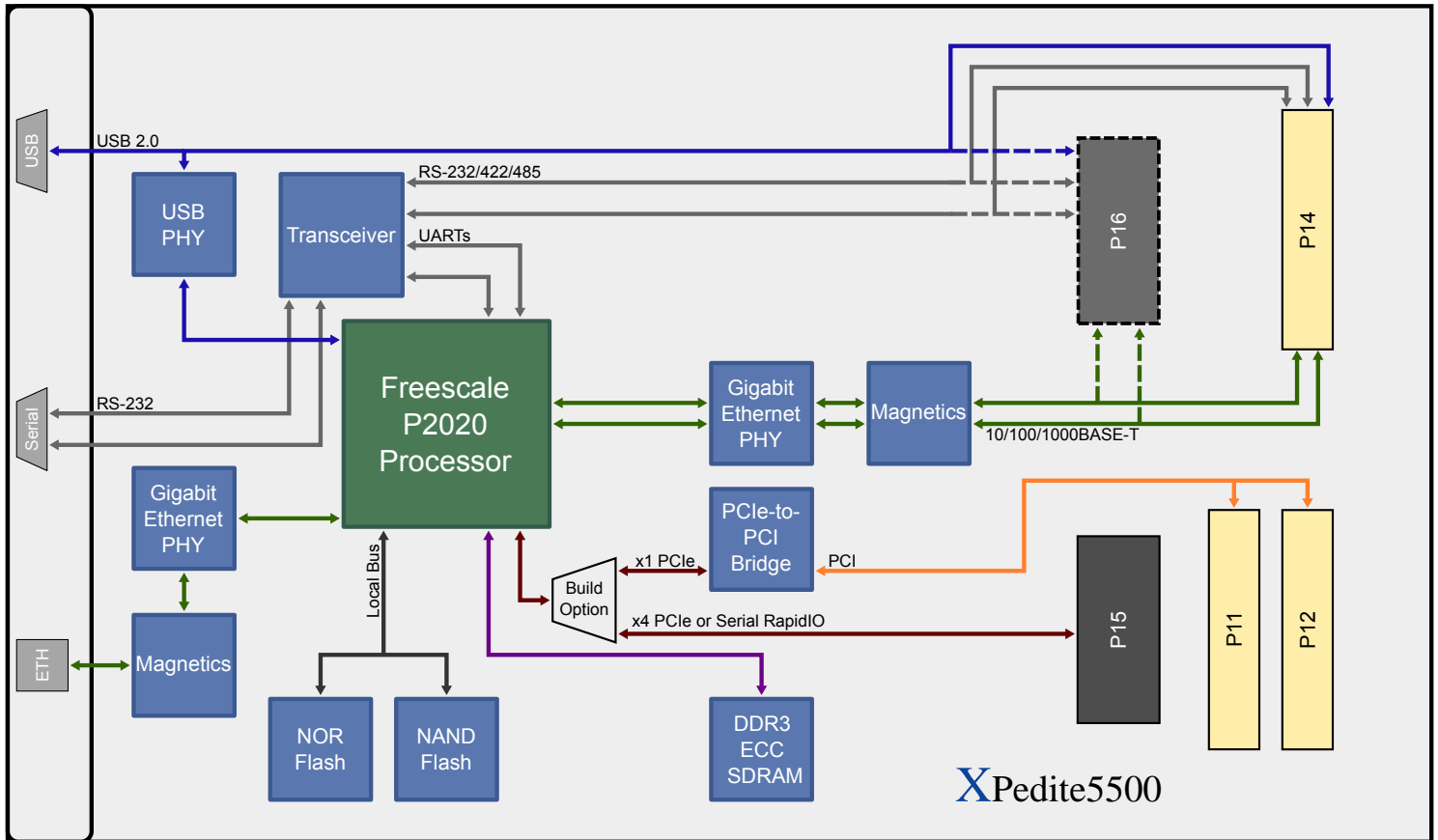

XPedite5500

