

# XPedite5401

NXP QorIQ Eight-Core P4080 Processor-Based Conduction-Cooled XMC/PMC Module with Two Gigabit Ethernet Ports

- ▶ NXP QorIQ P4080 processor with eight Power Architecture® e500mc cores at up to 1.5 GHz
- ▶ Alternate NXP QorIQ processors: P3041, P4040
- ▶ Conduction-cooled
- ▶ Extended shock and vibration tolerance
- ▶ Up to 8 GB of DDR3 ECC SDRAM in two channels
- ▶ Up to 256 MB of NOR flash (with redundancy)
- ▶ Up to 16 GB of NAND flash
- ▶ Hardware write-protection for NVRAM
- ▶ PCI PrPMC interface
- ▶ x4 PCI Express interface to P15
- ▶ XAUI to P16 (optional)
- ▶ Two Gigabit Ethernet ports to P14/P16
- ▶ Two USB 2.0 ports to P14/P16
- ▶ Two RS-232/422/485 serial ports to P14/P16
- ▶ Two SATA ports to P16 (optional)
- ▶ Linux BSP
- ▶ Wind River VxWorks BSP
- ▶ Green Hills INTEGRITY-178 tuMP BSP

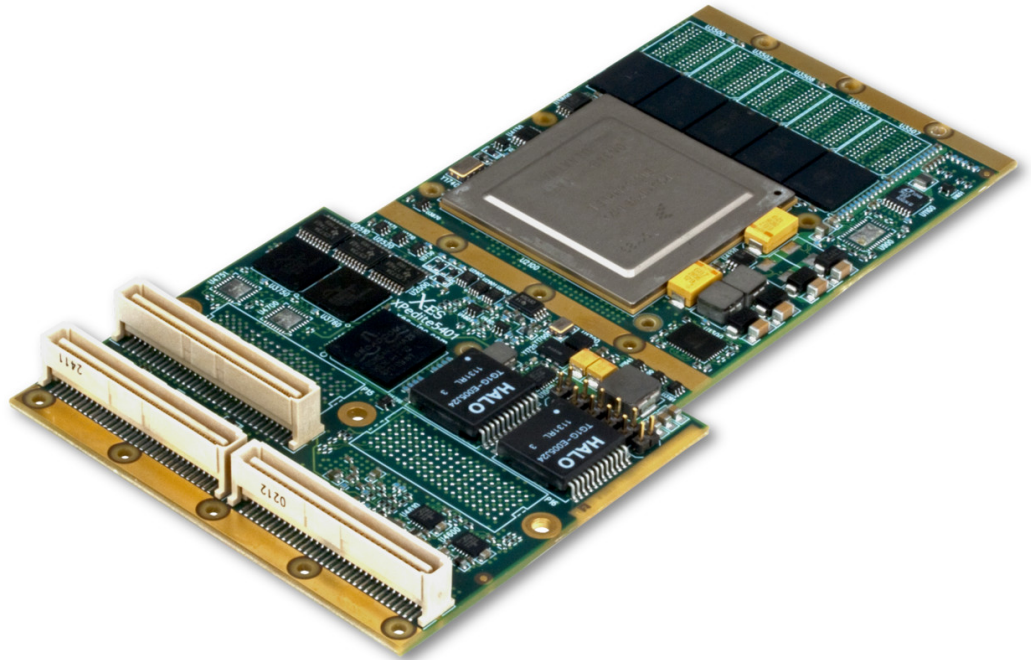

## XPedite5401

The XPedite5401 is a high-performance XMC/PrPMC supporting NXP (formerly Freescale) QorIQ P3 and P4 processors. With a number of processor options to choose from, X-ES can provide a product to meet the specific power and performance requirements of today's embedded computing applications.

The P4080 processor brings the raw power of eight e500mc cores running at up to 1.5 GHz and dual-channel DDR3 memory to deliver unparalleled multi-core performance. For applications that are more power-conscious, the P3041 processor offers four e500mc cores running at up to 1.5 GHz with a single channel of DDR3 memory, all within a significantly reduced power envelope. Additional reduced-function processors are available to meet any power and performance budget.

The XPedite5401 provides a high-performance, feature-rich solution for current and future generations of embedded applications. Wind River VxWorks, Linux and Green Hills INTEGRITY-178 tuMP Board Support Packages (BSPs) are available.

# X-ES

Extreme Engineering Solutions

*...Always Fast*

### Extreme Engineering Solutions

9901 Silicon Prairie Parkway • Verona, WI 53593  
 Phone: 608.833.1155 • Fax: 608.827.6171  
 sales@xes-inc.com • <https://www.xes-inc.com>

**Processor**

- NXP (formerly Freescale) QorIQ P4080 processor
- Eight Power Architecture® e500mc cores at up to 1.5 GHz
- 128 kB L2 cache per core
- 1 MB L3 cache per channel
- IEEE 754 Floating-Point Unit support

**Alternate Processor Configurations**

- P3041 processor with four Power Architecture® e500mc cores at up to 1.5 GHz
- P4040 processor with four Power Architecture® e500mc cores at up to 1.5 GHz

**Memory**

- Up to 8 GB of DDR3 ECC SDRAM in two channels
- Up to 256 MB of NOR flash (with redundancy)
- Up to 16 GB of NAND flash

**PrPMC Interface**

- 66/33 MHz PCI
- 32-bit bus interface

**P15 XMC Interface**

- x4 configurable PCI Express

**P14/P16 XMC/PMC Interface**

- Two 10/100/1000BASE-T Ethernet ports
- Two RS-232/422/485 serial ports
- 3.3 V GPIO
- Two USB 2.0 ports
- Two SATA ports capable of 3 Gb/s to P16 (optional)
- XAUI port to P16 (optional)

**Software Support**

- Linux BSP
- Wind River VxWorks BSP
- Green Hills INTEGRITY-178 tuMP BSP

**Physical Characteristics**

- Conduction-cooled XMC/PMC form factor
- Dimensions: 143.75 mm x 74 mm, 10 mm stacking height

**Environmental Requirements**

Contact factory for appropriate board configuration based on environmental requirements.

- Supported ruggedization levels (see chart below): 5
- Conformal coating available as an ordering option

**Power Requirements**

- Power will vary based on configuration and usage. Please consult factory.

Ruggedization Level	Level 1	Level 3	Level 5
Cooling Method	Standard Air-Cooled	Rugged Air-Cooled	Conduction-Cooled
Operating Temperature	0 to +55°C ambient †	-40 to +70°C ambient †	-40 to +85°C (board rail surface)
Storage Temperature	-40 to +85°C ambient	-55 to +105°C ambient	-55 to +105°C (maximum)
Vibration	0.002 g <sup>2</sup> /Hz (maximum), 5 to 2000 Hz	0.04 g <sup>2</sup> /Hz (maximum), 5 to 2000 Hz	0.1 g <sup>2</sup> /Hz (maximum), 5 to 2000 Hz
Shock	20 g, 11 ms sawtooth	30 g, 11 ms sawtooth	40 g, 11 ms sawtooth
Humidity	0% to 95% non-condensing	0% to 95% non-condensing	0% to 95% non-condensing

† Contact factory for airflow rate details.

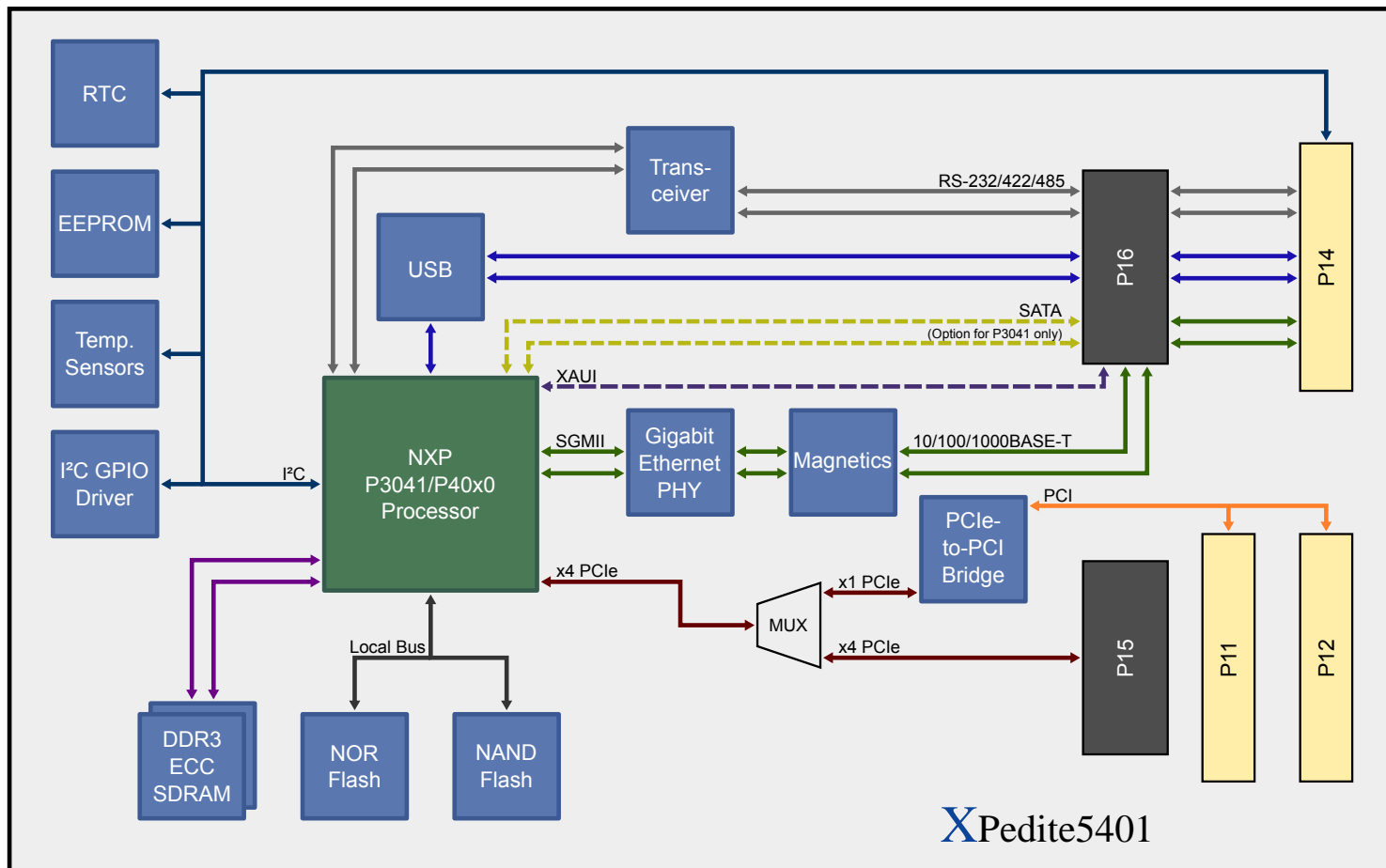

XPedite5401