

XPedite5551

NXP QorIQ P1021 Dual-Core Processor-Based Conduction- or Air-Cooled COM Express® Module Featuring the QUICC Engine™

- ▶ NXP QorIQ P1021 with dual Power Architecture® e500v2 cores at up to 800 MHz
- ▶ Conduction or air cooling
- ▶ COM Express® Mini form factor (55 mm x 84 mm)
- ▶ Extended shock and vibration tolerance
- ▶ Up to 2 GB of DDR3-667 ECC SDRAM
- ▶ Two x1 PCI Express interfaces
- ▶ Three Gigabit Ethernet ports
- ▶ One serial port
- ▶ One USB 2.0 port
- ▶ Up to 256 MB of NOR flash (with redundancy)
- ▶ Up to 32 GB of NAND flash
- ▶ Wind River VxWorks BSP
- ▶ Linux BSP
- ▶ Green Hills INTEGRITY-178 BSP
- ▶ QNX Neutrino (contact factory)
- ▶ LinuxWorks LynxOS (contact factory)

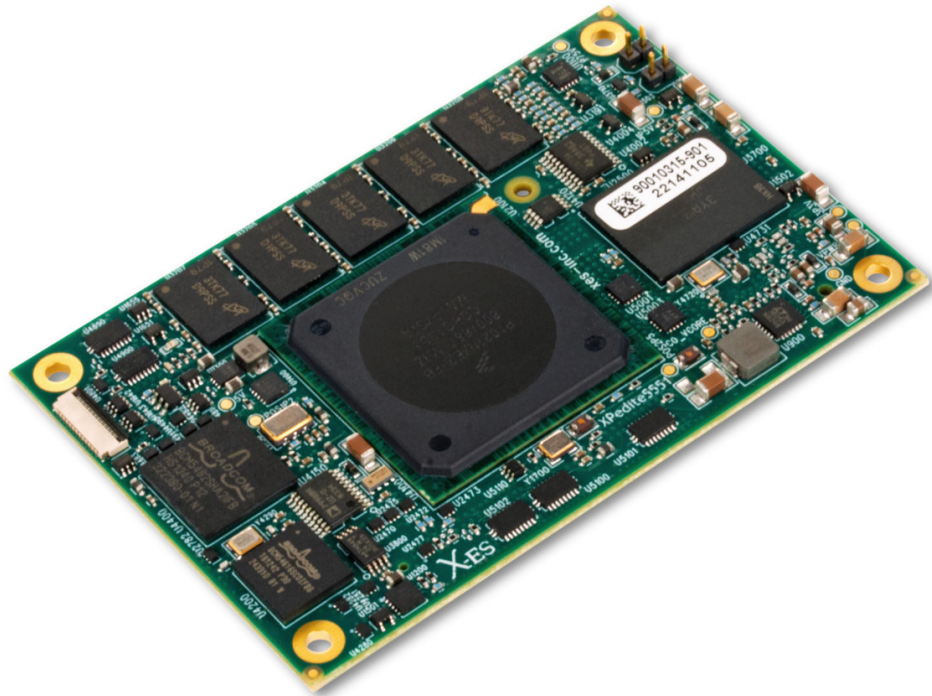

XPedite5551

The XPedite5551 is a ruggedized COM Express® Mini module based on the Type 10 specification featuring the QUICC Engine™. The XPedite5551 provides access to all 65 QUICC Engine™ signals, allowing customers to implement whichever communication protocol is needed for their application. Along with the dual Power Architecture® e500v2 cores running at up to 800 MHz, the NXP (formerly Freescale) QorIQ P1021 delivers enhanced performance and efficiency for today's network information processing and other computing applications.

The XPedite5551 complements processor performance with up to 2 GB of DDR3-667 ECC SDRAM. It also hosts numerous I/O ports, including three Gigabit Ethernet ports, two x1 PCIe ports, a single USB 2.0 port, one I²C port, one serial port, IEEE 1588 support, and the NXP QUICC Engine™.

The XPedite5551 provides a high-performance, feature-rich solution for current and future generations of embedded applications. For customers seeking lower overall power consumption, the XPedite5551 can be designed with the NXP QorIQ P1012 processor. Operating system support packages for the XPedite5551 include Wind River VxWorks, Green Hills INTEGRITY-178, and Linux.

X-ES

Extreme Engineering Solutions

...Always Fast

Extreme Engineering Solutions

9901 Silicon Prairie Parkway • Verona, WI 53593
 Phone: 608.833.1155 • Fax: 608.827.6171
 sales@xes-inc.com • <https://www.xes-inc.com>

Processor

- NXP (formerly Freescale) QorIQ P1021 processor
- Dual Power Architecture® e500v2 cores at up to 800 MHz
- 256 kB of shared L2 cache

Alternate Processor Configuration

- P1012 processor with one Power Architecture® e500v2 core at up to 800 MHz

Memory

- Up to 2 GB of DDR3-667 ECC SDRAM
- Up to 256 MB of NOR flash (with redundancy)
- Up to 32 GB of NAND flash

COM Express®

- Based on Type 10 pinout, see XPedite5551's User Manual for details
- Mini form factor (55 mm x 84 mm)

Ruggedization and Reliability

- Class III PCB fabrication and assembly
- Soldered DDR3 ECC SDRAM
- Tin whisker mitigation
- Designed and tested for extended solder joint reliability
- Additional mounting holes for rugged and conduction-cooled environments
- Bootloader and BIT support

Interface

- Three 10/100/1000BASE-T ports
- IEEE 1588
- Two PCIe x1 interfaces
- One USB 2.0 port
- I²C
- One TLL-level serial port
- NXP QUICC Engine™

Software Support

- Wind River VxWorks BSP
- Linux BSP
- Green Hills INTEGRITY-178 BSP
- QNX Neutrino (contact factory)
- LynuxWorks LynxOS (contact factory)

Environmental Requirements

Contact factory for appropriate board configuration based on environmental requirements.

- Supported ruggedization levels (see chart below): 1, 3, 5
- Conformal coating available as an ordering option

Power Requirements

- Power will vary based on configuration and usage. Please consult factory.

| Ruggedization Level | Level 1 | Level 3 | Level 5 |
|-----------------------|--|---|--|
| Cooling Method | Standard Air-Cooled | Rugged Air-Cooled | Conduction-Cooled |
| Operating Temperature | 0 to +55°C ambient (300 LFM) | -40 to +70°C (600 LFM) | -40 to +85°C (board rail surface) |
| Storage Temperature | -40 to +85°C ambient | -55 to +105°C ambient | -55 to +105°C (maximum) |
| Vibration | 0.002 g ² /Hz (maximum), 5 to 2000 Hz | 0.04 g ² /Hz (maximum), 5 to 2000 Hz | 0.1 g ² /Hz (maximum), 5 to 2000 Hz |
| Shock | 20 g, 11 ms sawtooth | 30 g, 11 ms sawtooth | 40 g, 11 ms sawtooth |
| Humidity | 0% to 95% non-condensing | 0% to 95% non-condensing | 0% to 95% non-condensing |

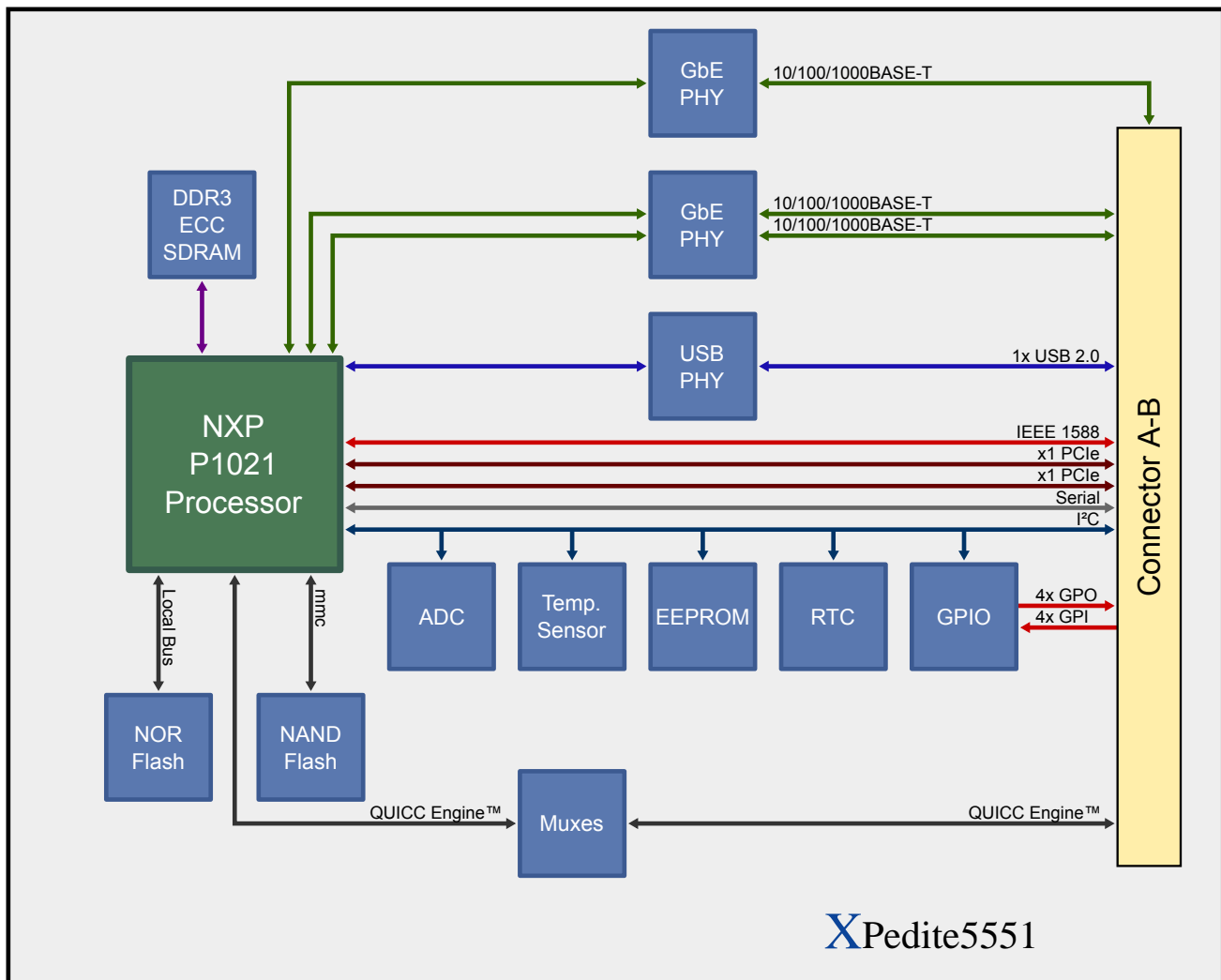

XPedite5551